

RESILIENT SEAL SWING CHECK VALVE (NON RETURN VALVE) FOR FIRE MAIN MODEL 120 U

Valves are manufactured and tested in accordance with UL 312, FM, ULC class 175. The valve designed to offer positive seating for resistance against back pressure of back flow and efficient relax surge in line, suitable for fire protection and distribution service.

SIZE : 2 1/2" - 12"



Fig.378

QUALITY CERIFIED BY :



LISTED NO.34S2



APPROVED NO. 1210



LISTED NO.2100 122.3

FEATURES

- Class 175 (350 psi non-shock pressure)
- Flange conforms with ANSI B16.1 , class 125
- Full port and easy in-line service
- Replaceable resilient disc seat and disc
- Disc - body clearance min. 19.1 mm.
- Arm - body clearance min. 12.7 mm.
- Lifting lug on cover
- Epoxy coated internal and external

DESIGN SPECIFICATIONS

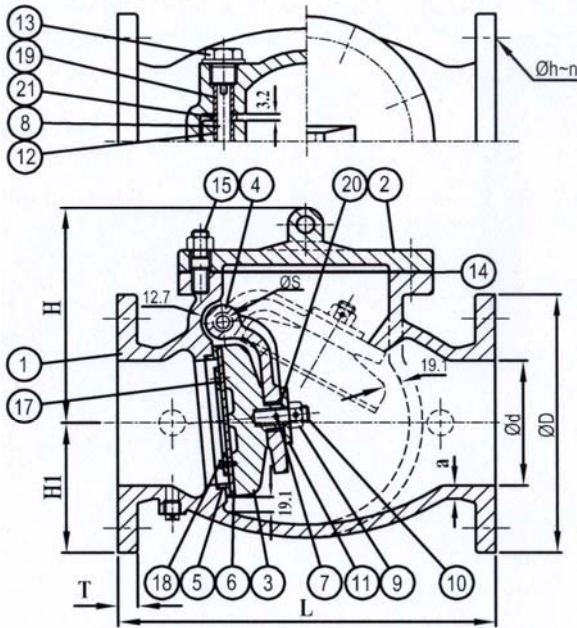

Fig.378

NO.	PARTS	MATERIALS	ASTM. DESIGNATION
1	Body	Cast Iron	A 126 Class B
2	Cover	Cast Iron	A 126 Class B
3	Disc	Cast Iron	A 126 Class B
4	Arm	Cast Iron	A 126 Class B
5	Body Seat	Bronze	B62
6	Disc Seat	Rubber (Buna-N)	D 2000 AA 6014
7	Knock Pin	Stainless Steel	A 276 Type 304
8	Hinge Pin	Stainless Steel	A 276 Type 304
9	Disc Nut	Brass	B36
10	Disc Stud	Brass	B36
11	Washer	Brass	B36
12	Arm Bushing	Bronze	B62
13	Plug	Brass	B36
14	Cover Gasket	Rubber (NR)	D 2000 AA 6014
15	Cover Stud Nut	Steel	A 307 Grade B
16	O-Ring	Rubber (NR)	D 2000 AA 6014
17	Seat Holder	Bronze	B62
18	Seat Bolt	Stainless Steel	A 276 Type 304
19	Body Bushing	Bronze	B62
20	Arm Disc Bushing	Bronze	B62
21	Spacer	Bronze	B62

SIZE in d	mm	L	Flanged ANSI B 16.1CL.125					a	S ^Ø	H	H1	Approx.Weight	
			D ^Ø	C ^Ø	h ^Ø	n	T					Kgs	lbs.
2 1/2"	65	216	178	140	19	4	17.5	10	9.5	167	89	20.0	44.0
3	80	241	191	152	19	4	19	12	9.5	190	95.5	23.0	50.6
4	100	292	229	191	19	8	23.8	13	9.5	211	114.5	36.0	79.2
6	150	356	279	241	22.2	8	25.4	16	15.9	269	139.5	69.0	151.8
8	200	495	343	299	22.2	8	28.6	18	19.1	310	171.5	142.0	312.4
10	250	622	406	362	25.4	12	30.2	21	22.2	352	203	210.0	462.0
12	300	698	483	432	25.4	12	31.8	23	22.2	413	241.5	300.0	660.0



Siam Cast Iron Works Co.,Ltd.

Factory: 1/12 Moo 2, Samutsakorn Industrial Estate, Soi 7,

Rama II Road, Muang, Samutsakorn 74000, Thailand

Tel: (6634)829-200 Fax: (6634)829-222 E-mail: sci@scivalve.com



ISO 9001
File No. A4645