

GATE VALVE (WATERWORKS AND WASTE WATER)

Valves are manufactured and tested in according to AWWA C509, BS563:86-A,B , BS 5150 (Size 700 and above) , ISO 7259 , DIN 3352 PART 2&3, TIS 256 and also meet the requirement of MSS-SP-70 class 125 / 250 ect. Face to Face comply with ANSI B16.10 , BS 5163 , BS 5150 (Size 700 and above) DIN 3202 F4 & F5 , ISO 5752 Series 3 / 14 / 15 / 19
Rated Pressure PN 10 , 16 , 25 , 40. Non rising stem and rising stem OS&Y. Valves are desinged for Vertical , Horizontal and Flat position all types of water, air and steam.

SIZE : 50 mm. - 2000 mm.

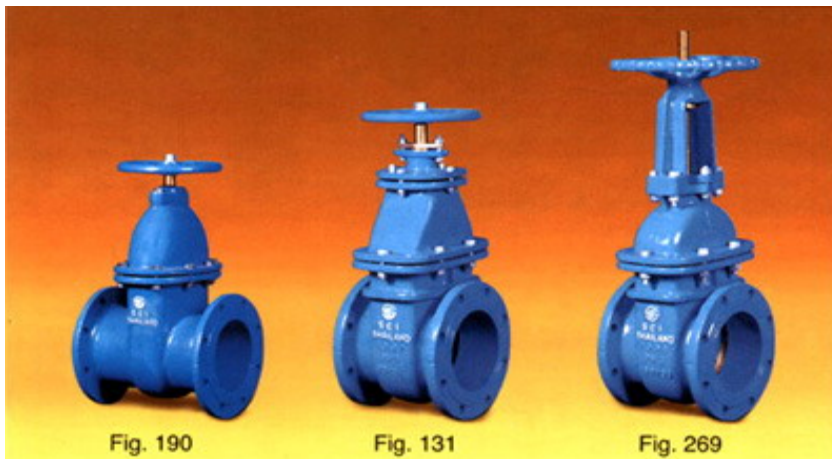

FEATURES

- IBBM (iron body and bronze mounted) , stainless steel trim , and all iron trim is also available.
- Valve ends can be flanged , spigot , socket , mechanical joint , grooved and shoulder.
- Flanged drilling to suit ANSI B16.1 , BS4504 , BS10 , BS 4772 , ISO , AS 2129 , DIN , JIS and etc.
- Various types of operators such as handwheel , chainwheel , spur gear , bevel gear, pneumatic , hydraulic and electric actuator can be provided upon requested.
- Special accessories like by-pass unit , valve locking device , tapped bosses , indicator and limit switches are also available.

VALVE FIGURES NO.

Fig .131 Non Rising Stem , with Handwheel or Chainwheel or Cap or Operating Nut or Actuator.

Fig .152 Non Rising Stem , with Gear and Handwheel or Chainwheel or Cap or Operating Nut or Actuator.

Fig .152 Rising Stem OS&Y , with Handwheel or Chainwheel or Actuator.

Fig .190 Ductile iron valve Non Rising Stem size 50 - 300 mm. with Handwheel or Chainwheel or Actuator.

DESIGN SPECIFICATIONS

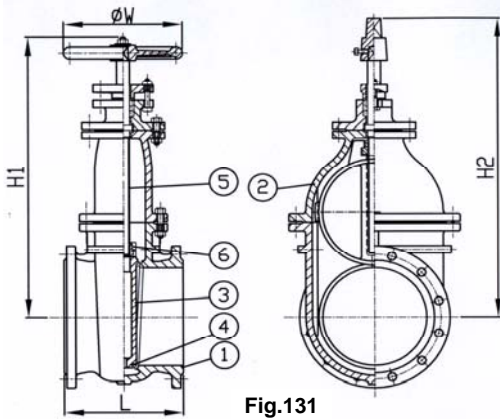

Fig.131

SIZE	L	H1	H2	ØW	WEIGHT (kg.)	No OF TURN
DN	PN.10 16	(mm.)	(mm.)	(mm.)	REF PN.10	TURN
50	178	310	400	180	12	4.5
80	203	397	480	200	20	7
100	229	440	523	224	35	9
150	267	536	619	250	58	13
200	292	602	684	280	100	17.5
250	330	696	774	315	143	22
300	356	785	863	355	219	26
350	381	945	1015	400	366	30
400	406	1075	1145	450	488	34.5
450	432	1160	1235	500	590	39
500	457	1275	1350	623	840	43
600	508	1490	1565	623	1202	51.5

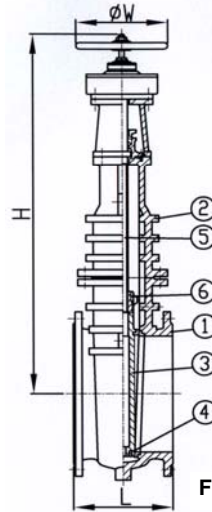

Fig.152

SIZE	L	H	ØW	WEIGHT (kg.)	No OF TURN
DN	PN.10 16	(mm.)	(mm.)	REF PN.10	TURN
350	381	1120	400	386	75
400	406	1285	450	577	104
450	432	1370	450	638	117
500	457	1470	450	949	129
600	508	1730	500	1483	206
700	610	2024	500	2092	340
800	660	2190	623	2853	585
900	711	2376	623	3816	546
1000	811	2730	623	5156	810
1200	838	2920	623	7730	970
1400	860	3412	623	11000	1700
1500	900	3570	623	13000	2183
1600	965	3627	623	15100	2048
1800	1300	3990	623	20800	3062
2000	1400	4400	623	27500	3393

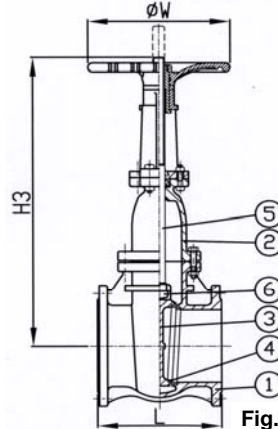

Fig.269

SIZE	L	H3	ØW	WEIGHT (kg.)	No OF TURN
DN	PN.10 16	(mm.)	(mm.)	REF PN.10	TURN
50	178	343	160	13	13
80	203	418	198	23	20
100	229	500	250	39	25
150	267	664	300	68	31
200	292	814	355	113	41
250	330	969	395	170	51
300	356	1111	450	238	49

NO.	PARTS NAME	MATERIAL	ASTM.DESIGNTION	BS.STANDARD	DIN.STANDARD
1	Body	Cast Iron	A 126 Class B	1452 Gr. 220,250,300	1691 GG25
2	Bonnet	Ductile Iron	A 536 Grade 65-45-12	420/12	
3	Disc	(Spheroidal Graphite Iron)	A 536 Grade 80-55-6 A 395	2789 Gr. 500/7 600/3	163 GGG 50
4	Seat	Bronze	B 62	1400 LG.2	1705 G-CuSn5ZnPb
		Stainless Steel	A276 Type 304,316,316L,431	970 Gr. 304S15 316S16 316S12(316L) 431S29	17440 X5CrNi 1810 17440 X5CrNiMo 17122 17440 X2CrNiMo 17132 17440 X17CrNi 16-2
5	Stem	Copper Alloy	B16 B21	2872 CZ 114	17660 CuZn 40
		Stainless Steel	A276 Type 304,316,316L,431	970 Gr. 304S15 316S16 316S12(316L) 431S29	17440 X5CrNi 1810 17440 X5CrNiMo 17122 17440 X2CrNiMo 17132 17440 X17CrNi 16-2
		Aluminium Bronze	B 124 B 150	2872 CA 104	17672 CuAl10Ni5Fe4
6	Stem Nut	Aluminium Bronze	B148 C95200	1400 AB.1	1714 CuAl10Fe
		Bronze	B 62	1400 LG.2	1705 G-CuSn5ZnPb
		Stainless Steel	A276 Type 304,316,316L,431	970 Gr. 304S15 316S16 316S12(316L) 431S29	17440 X5CrNi 1810 17440 X5CrNiMo 17122 17440 X2CrNiMo 17132 17440 X17CrNi 16-2



Siam Cast Iron Works Co.,Ltd.

Factory: 1/12 Moo 2, Samutsakorn Industrial Estate, Soi 7,
Rama II Road, Muang, Samutsakorn 74000, Thailand

Tel: (6634)829-200 Fax. (6634)829-222 E-mail: sci@scivalve.com



ISO 9001
File No. A4645