

**PENSTOCK**

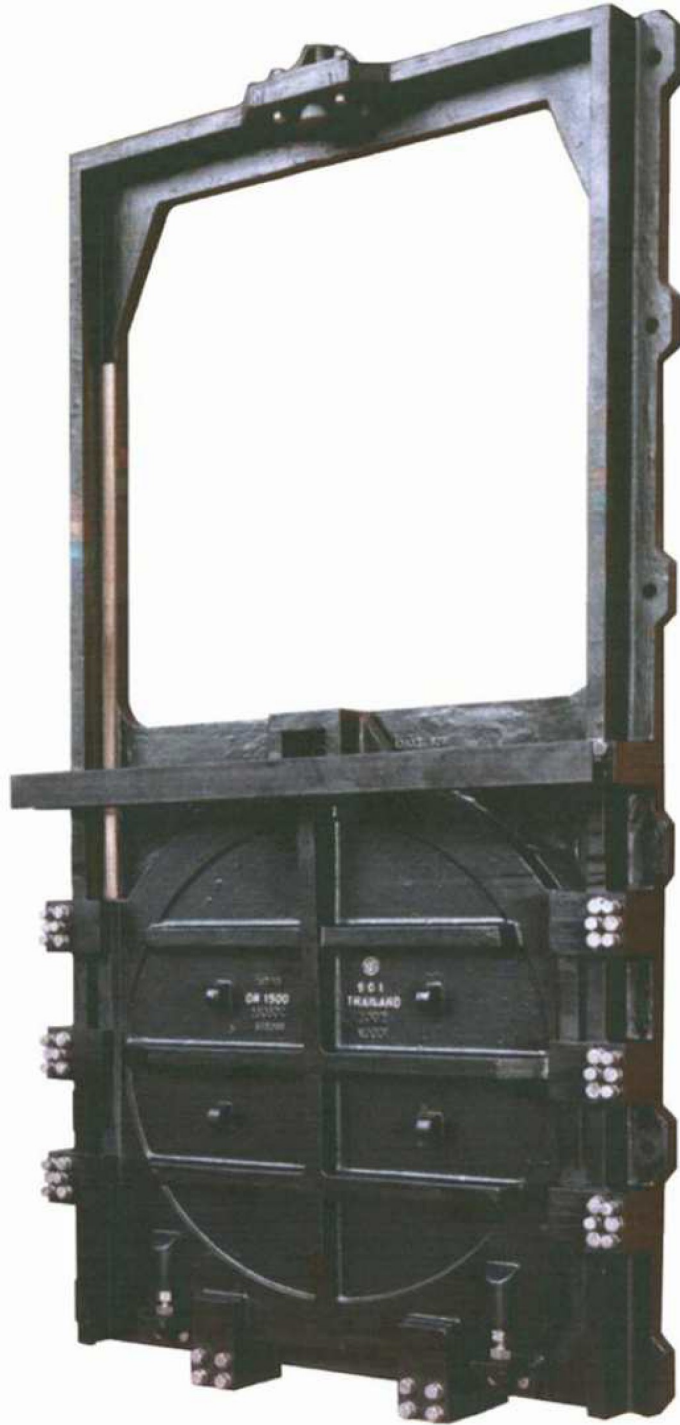

**ROBUST CONSTRUCTION  
CUSTOMIZED DIMENSIONS**

**SCI CORPORATION CO.,LTD.**

**A) TYPICAL PENSTOCK ARRANGEMENT**

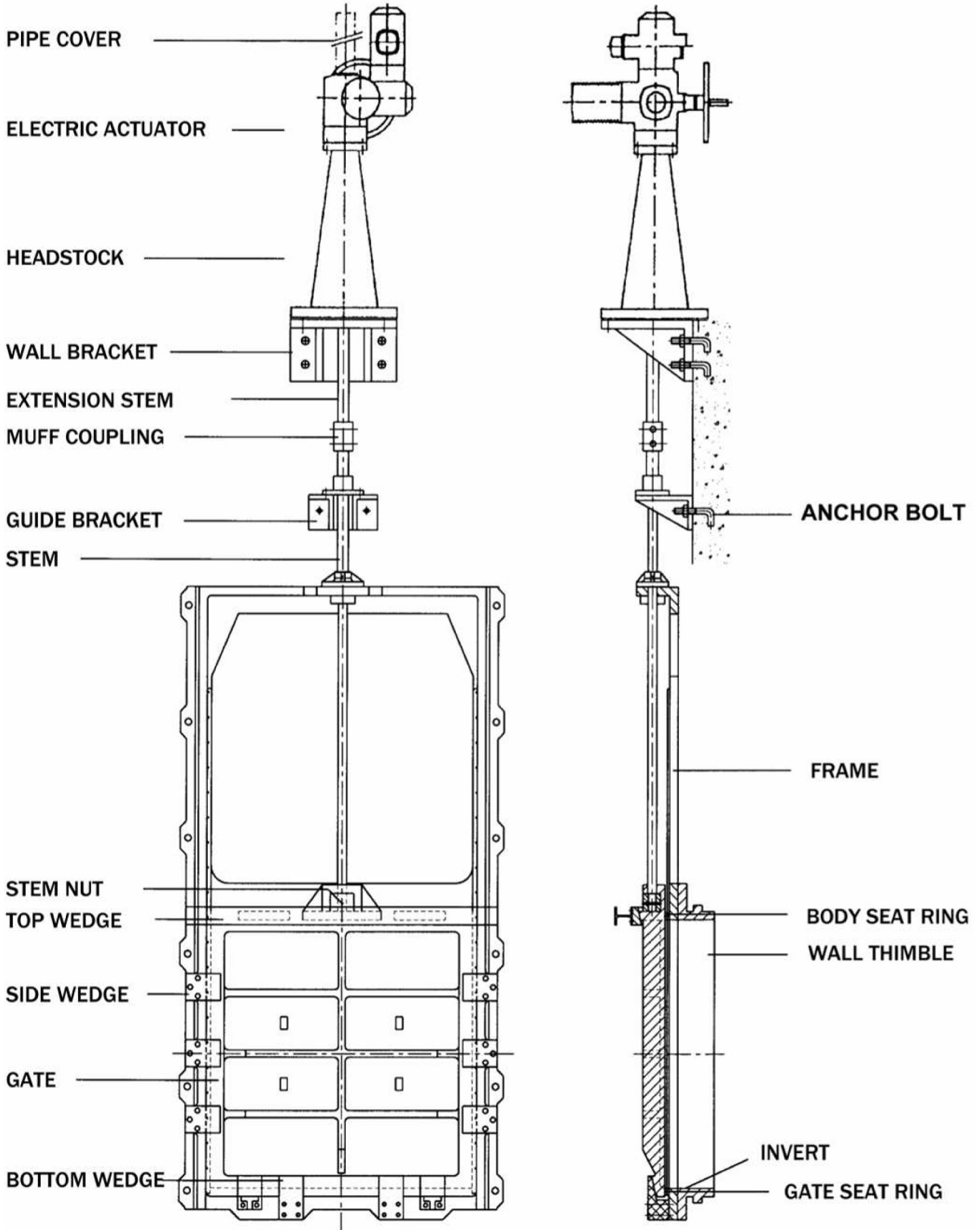

[www.scivalve.com](http://www.scivalve.com)

## B) PENSTOCK DESIGN

### 1. PARTS FEATURE

#### 1.1. Frames and Gates

Materials are in high duty cast iron constructed with substantial ribbing for resistance to deflection. Frames connection are flat back or spigot type for extending into concrete, spigot end type provide extra stiffening to the frame. As for circular and rectangular penstocks, flanges connection are also available on request, These types of connection are used to enable bolting installation to flange inlet pipe and wall thimble installation. On each side of the frame, guide channels are provided for the gate and extended to a sufficient height to ensure that the gate is supported over not less than two-thirds of its depth when at maximum lift.

#### 1.2. Body Seat, Gate Seat

These consist normally of bronze seating strips of heavy rectangular sections pinned to machined surfaces on body and gate which are then ground in together to a watertight bearing. Bronze strips are also fitted as bearing surfaces in the guides into which the gate lifts. For sea-water or sewage, aluminium bronze is used or alternatively stainless steel.

#### 1.3. Wedges

On each side of the frame are cast iron cover bars extending vertically down with adjustable block for limiting the downward movement of the gate. These where tight closure is required and when under pressure forcing the gate away from the frame, additional top and bottom wedges are provided. When strong support is required due to heavy loading, top wedging is a cast iron wedge bar spanning the gate, having taper faces against which the gate wedges work. The number of wedges provided varies according to the size and shape of the penstock and the pressure conditions.

#### 1.4. Stems

Both rising and non-rising stem construction are available. In the non-rising form the operating threads engage a tapped lifting nut housed between lugs at the head of the gate, the gate itself being cast with a barrel to accommodate the projection of the stem at open positions. In the rising type, the stem is bolted to the stem nut and has the operating thread at the upper end where it engages a revolving nut in the actuator.

All stems are suitable sized for duty and furnished with machine-cut thread of stub acme form. High grade materials appropriate to the service requirements are used, the selection of which is based on such factors as the nature of the fluid to be handled, the operating load, the distance from gate to actuator, etc. aluminium bronze and stainless are alternatives and regularly employed

## 2. MATERIALS OF CONSTRUCTION

| PARTS                                      | TYPES   |   |   |
|--|---|---|---|
|  | CI SERIES   | SG SERIES   | SS SERIES   |
| FRAME                                      | CAST IRON<br>ASTM A 126 CLASS B<br><i>BS EN 1561-EN-GJL-250</i>           | SG IRON ( DUCTILE IRON )<br>ASTM A 536 GRADE 65-45-12<br><i>BS EN 1563-EN-GJS-500-7</i> | STAINLESS STEEL<br>ASTM A 276 TYPE 304,316<br><i>BS 970 GRADE 304,316</i> |
| GATE                                       | CAST IRON<br>ASTM A 126 CLASS B<br><i>BS EN 1561-EN-GJL-250</i>           | SG IRON ( DUCTILE IRON )<br>ASTM A 536 GRADE 65-45-12<br><i>BS EN 1563-EN-GJS-500-7</i> | STAINLESS STEEL<br>ASTM A 276 TYPE 304,316<br><i>BS 970 GRADE 304,316</i> |
| STEM                                       | STAINLESS STEEL<br>ASTM A 276 TYPE 304,316<br><i>BS 970 GRADE 304,316</i> | STAINLESS STEEL<br>ASTM A 276 TYPE 304,316<br><i>BS 970 GRADE 304,316</i>               | STAINLESS STEEL<br>ASTM A 276 TYPE 304,316<br><i>BS 970 GRADE 304,316</i> |
| STEM NUT                                   | GUNMETAL<br>ASTM B 62<br><i>BS EN 1982-CC491K</i>                         | GUNMETAL<br>ASTM B 62<br><i>BS EN 1982-CC491K</i>                                       | GUNMETAL<br>ASTM B 62<br><i>BS EN 1982-CC491K</i>                         |
| BODY SEAT<br>GATE SEAT                     | GUNMETAL<br>ASTM B 62<br><i>BS EN 1982-CC491K</i>                         | GUNMETAL<br>ASTM B 62<br><i>BS EN 1982-CC491K</i>                                       | GUNMETAL<br>ASTM B 62<br><i>BS EN 1982-CC491K</i>                         |
|  | STAINLESS STEEL<br>ASTM A 276 TYPE 304,316<br><i>BS 970 GRADE 304,316</i> | STAINLESS STEEL<br>ASTM A 276 TYPE 304,316<br><i>BS 970 GRADE 304,316</i>               | STAINLESS STEEL<br>ASTM A 276 TYPE 304,316<br><i>BS 970 GRADE 304,316</i> |
| TOP WEDGE                                  | STEEL<br>ASTM A 36<br><i>BS 1506</i>                                      | STEEL<br>ASTM A 36<br><i>BS 1506</i>  | STEEL<br>ASTM A 36<br><i>BS 1506</i>                                      |
| BOTTOM WEDGE<br>SIDE WEDGE<br>WALL THIMBLE | CAST IRON<br>ASTM A 126 CLASS B<br><i>BS EN 1561-EN-GJL-250</i>           | SG IRON ( DUCTILE IRON )<br>ASTM A 536 GRADE 65-45-12<br><i>BS EN 1563-EN-GJS-500-7</i> | STAINLESS STEEL<br>ASTM A 276 TYPE 304<br><i>BS 970 GRADE 304</i>         |
|  | STAINLESS STEEL<br>ASTM A 276 TYPE 304,316<br><i>BS 970 GRADE 304,316</i> | STAINLESS STEEL<br>ASTM A 276 TYPE 304,316<br><i>BS 970 GRADE 304,316</i>               | STAINLESS STEEL<br>ASTM A 276 TYPE 304,316<br><i>BS 970 GRADE 304,316</i> |

## 3. DESIGN FEATURES

- 1 Simple Installation
- 2 Reduced Operation Torque
- 3 Cast Iron, Ductile Iron, Fabricated Stainless Steel and Fabricated Steel
- 4 Meet the requirement of AWWA C-501 : 1992, BS 7775 : 1995

## 4. GATE OPENINGS

Three types of opening are available

- 1 Square
- 2 Rectangular (Width x Height)
- 3 Round

## 5. APPLICATIONS

- Sewage Treatment Plants
- Water Works
- Power Plants
- Flood Control Projects
- Dams
- Industrial Water Control Projects

### C) OPERATOR OPTION

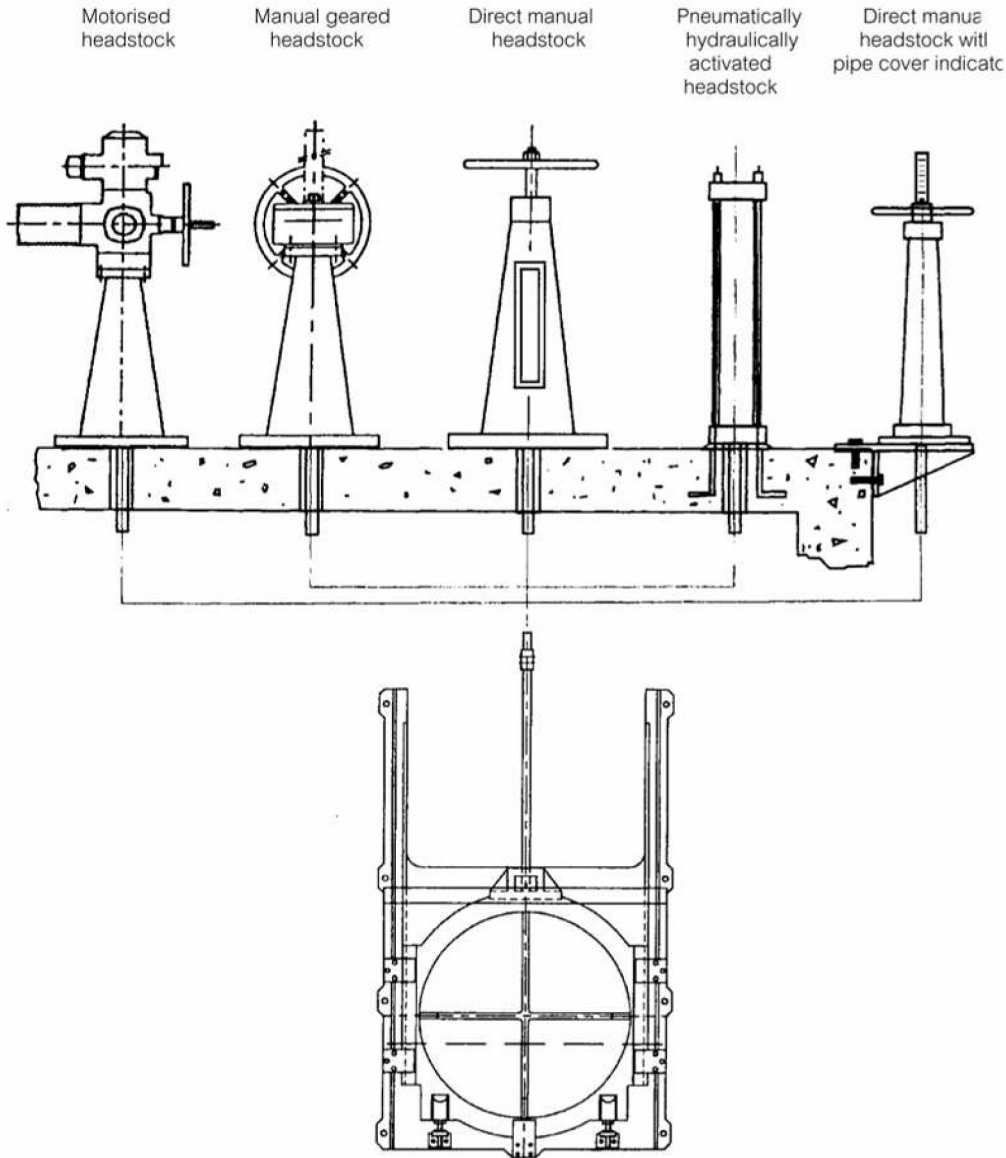

Headstocks cone is a variety of formats. Depending on the end-users requirement, special custom-designed headstocks or gate opening mechanisms can also be manufactured. SCI has a standard headstock range to choose from:

- Motorised
- Pneumatically / Hydraulically activated
- Manual geared
- Direct manual with indicator
- Direct manual with pipe cover indicator

## D) ACCESSORIES

### Extension Stem

Normally in mild steel, aluminium bronze or stainless steel are available for special applications. The maximum one piece lengths available in mild steel is approximately 3 metres. Other materials in shorter length. Rising or non-rising extension stems above 3 metres in length or extension stem in differing planes need supplementing by the use of a stem adaptor, muff coupling or universal joint.



### Stem Adaptor

In cast iron and ductile iron for joining straight lengths of stem in line, and for torsional loads only.



### Muff coupling

For joining two straight lengths of stem in line, and for axial and torsional loads. Normally in cast iron and ductile iron but certain other corrosion resistant materials are also available.

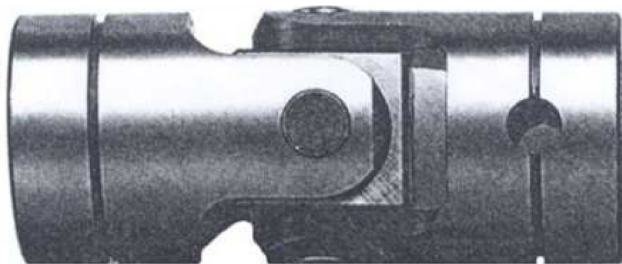

### Universal Joint

For joining two straight lengths of stem, in differing planes and for transmission of torsional loads only. Normally in mild steel but certain other corrosion resistant materials are available.

## Wall Bracket

Wall brackets are used to support head stock or extension stem. When no concrete work or suitable floor exists in the operating area. Manufactured in cast iron, the brackets are designed to withstand all normal operating loads.

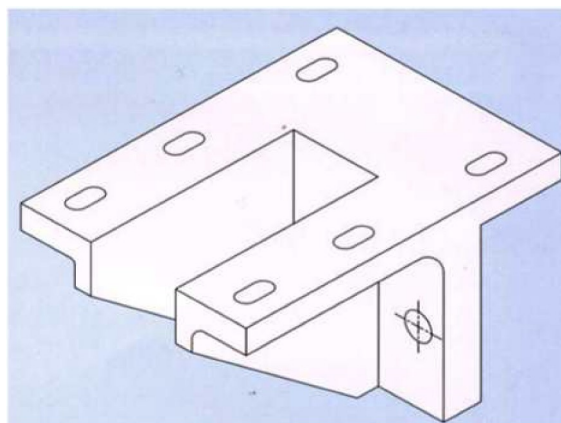

## Guide Bracket

In some instances unsupported lengths of stem are subjected to buckling under compression or from thrust by debris or solids. Stem guides are therefore , necessary as a means of supplying intermediate support. The bolt on type adjustable guides are in cast iron normally plain unmachined but can be bronze bushed if required. A complete range of stock sizes are available. The maximum unsupported stem length is normally 2.5 m to 3.0 m. Fabricated mild steel build in bolt on type stem brackets are available for outreaches greater than 760 mm.

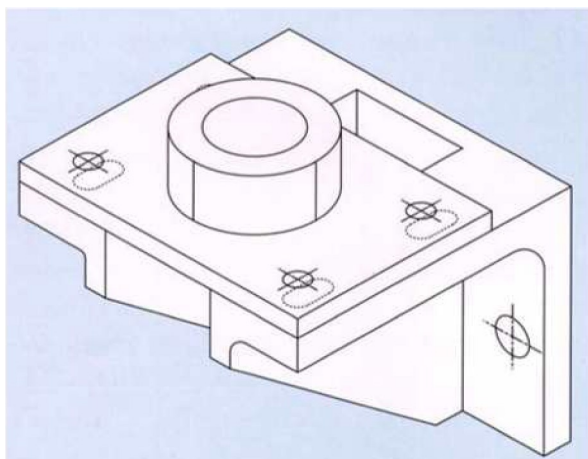

## Wall Thimble

Use of a wall thimble is the recommended method of mounting the gate because it provides a rigid machined mounting surface.

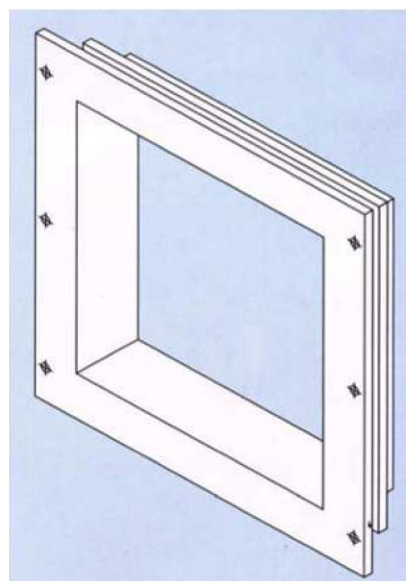
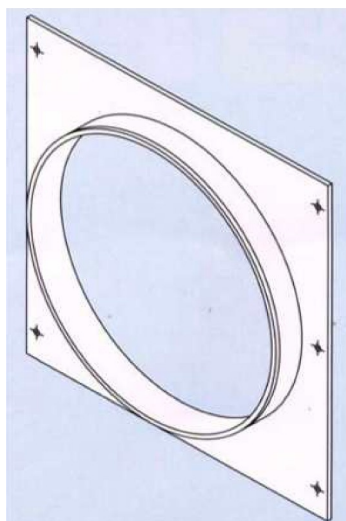

## E) SEATING ARRANGEMENT

### Type of Operations

#### On Seating

Pressure forcing the door onto the frame.

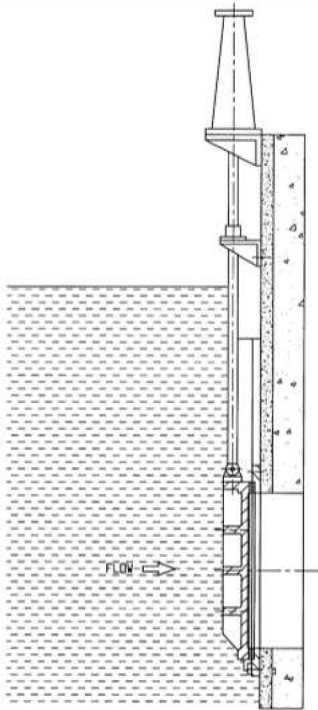

#### Off Seating

Pressure forcing the door away from the frame.

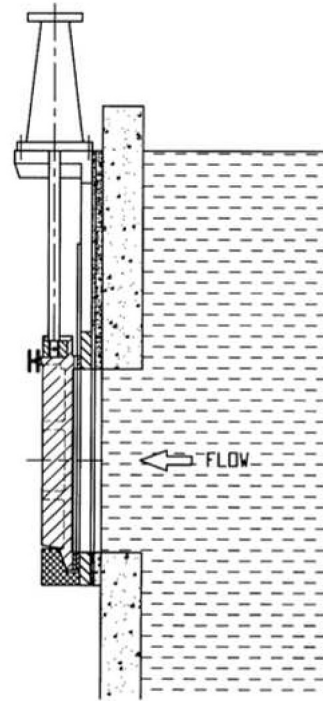

#### On-Off Seating - Pressure action on both sides

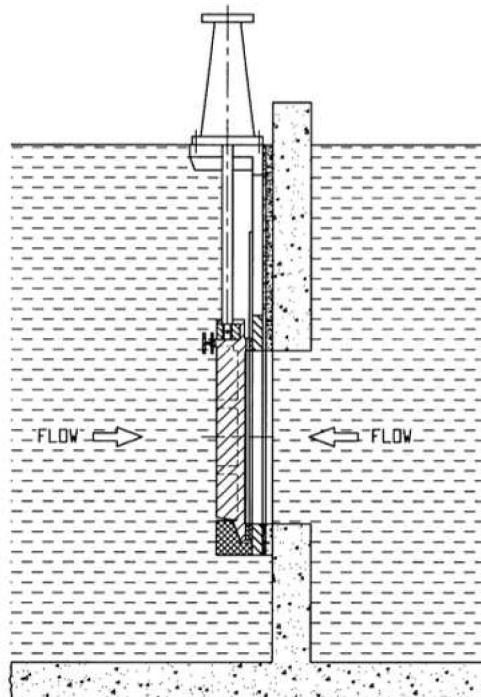

The special consideration must be taken when modulating weir penstock are used to control flow purposes and the gate frequently repositioned utilizing only a proportion of its full stroke.

[www.scivalve.com](http://www.scivalve.com)





## F) THE ADVANTAGES OF FLUSH BOTTOM PENSTOCK

### Flush Bottom Penstock

Flush bottom penstock design is used wherever a continuous smooth opening is desirable. Typical installations include wastewater setting tanks, aeration tanks, and sedimentation and flocculation basins.

The advantages of this penstock is to prevent the rubbish stay or block at the slot between the bottom of the penstock and the mounted wall. This is used for preventing the gate operation stuck and water leakage cause by the stuck at the bottom gap.

This penstock is providing a flat plane across the bottom of frame while the gate is opened by using the EPDM seal. The seal is mounted to the frame with stronger support by corrosion resistant fasteners. The EPDM seal is design for easy replaceable without dismantle the frame. Bottom wedges are not used with a flush bottom closure.

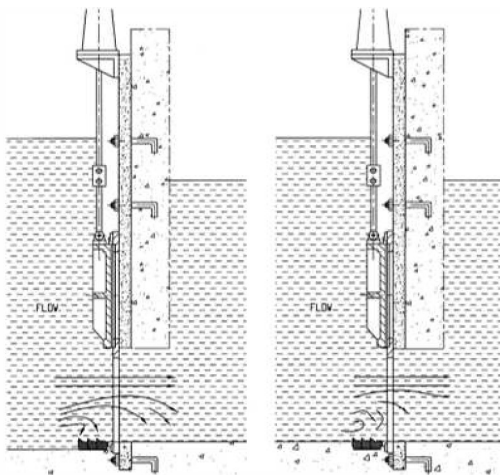
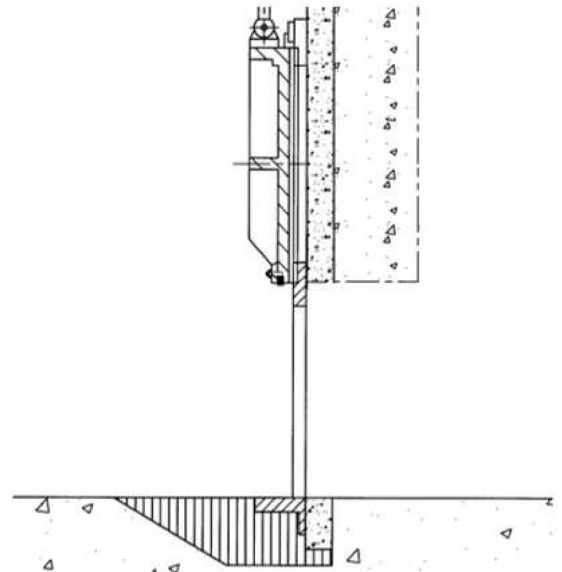

Rubbish Blocking Problem

Non Fully Discharge Problem

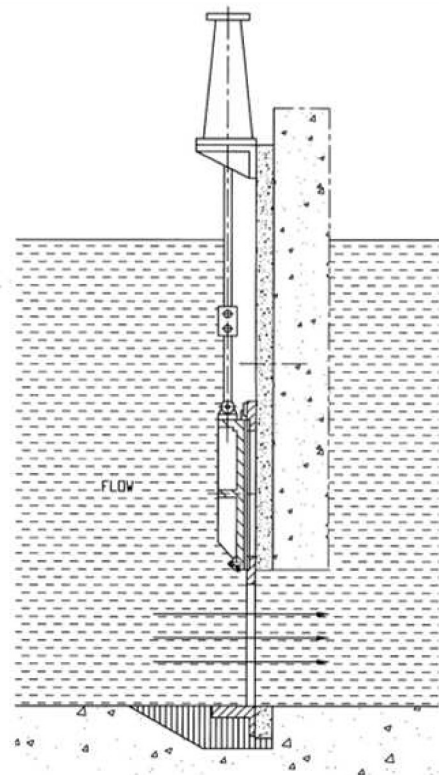

Solution of Flush Bottom Penstock

## G) TYPE OF CAST IRON & DUCTILE IRON PENSTOCK / SLUICE GATE

### Standard Flat Back

This is the most popular heavy duty type of penstock used in wide variety of water application for water treatment plant and flood control. SCI standard flat back penstock with casting in cast iron, ductile iron design comply with AWWA C-501 : 1992 and BS 7775 : 1995 requirement. The penstock is designed for standard 10.0 m ON/OFF seating head with rising and non-rising stem optional. The frame and gate are shot blasted to SA 2.5 and immediately painted by high solid epoxy paint with good corrosive resistance behaviors. The corrosion resistant adjustable side wedges and top / bottom wedges created the good sealing surface for long life used. All the assembly hardware are of corrosion resistant material.

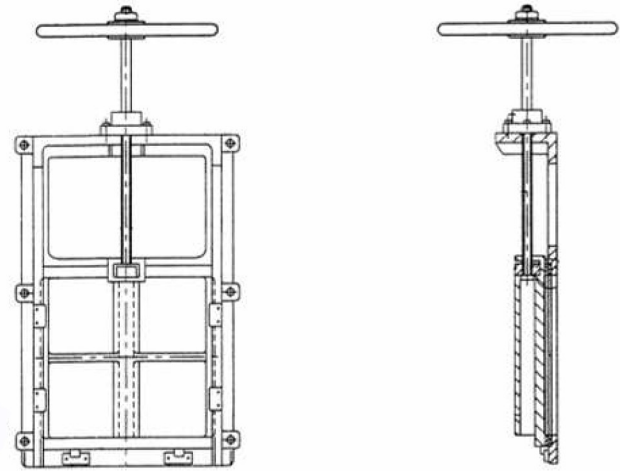

**Standard Flat Back**

### Standard Spigot Back

The spigot back gate opening include square, rectangular and circular opening. Those shapes of opening are also available in spigot type of penstock. Spigot back of penstock is designed for easy install and preventing the misalign of the aperture fitting.

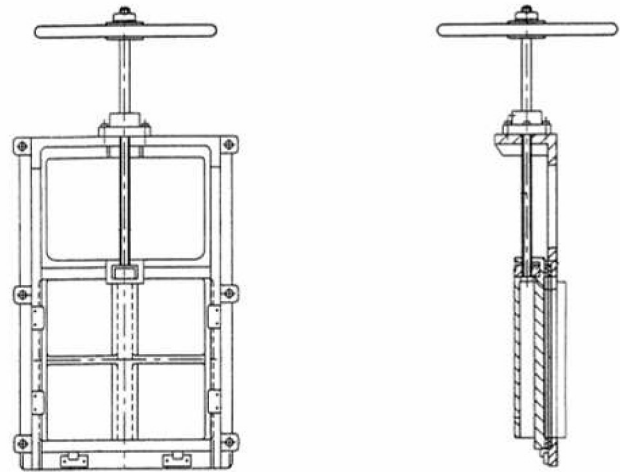

**Spigot Back**

### Weir Gate

The SCI weir gate is used to control the water level for modulating service. The weir gate is designed with contact surface bronze to bronze to reduce excessive wear due to modulating service.

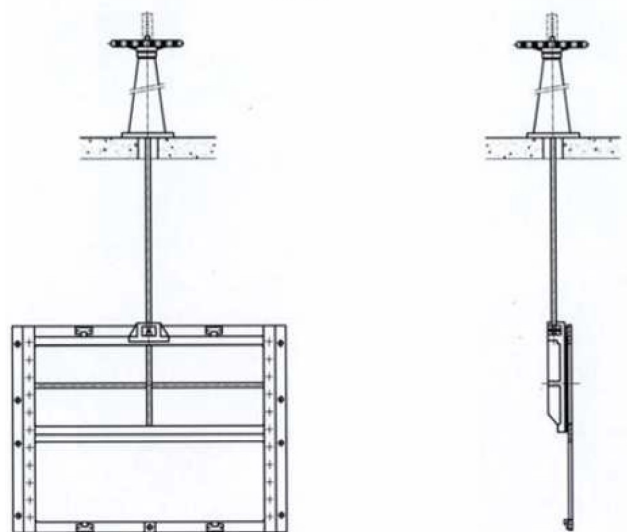

**Weir Gate**

## H) THE WEDGE SYSTEM DETAILS

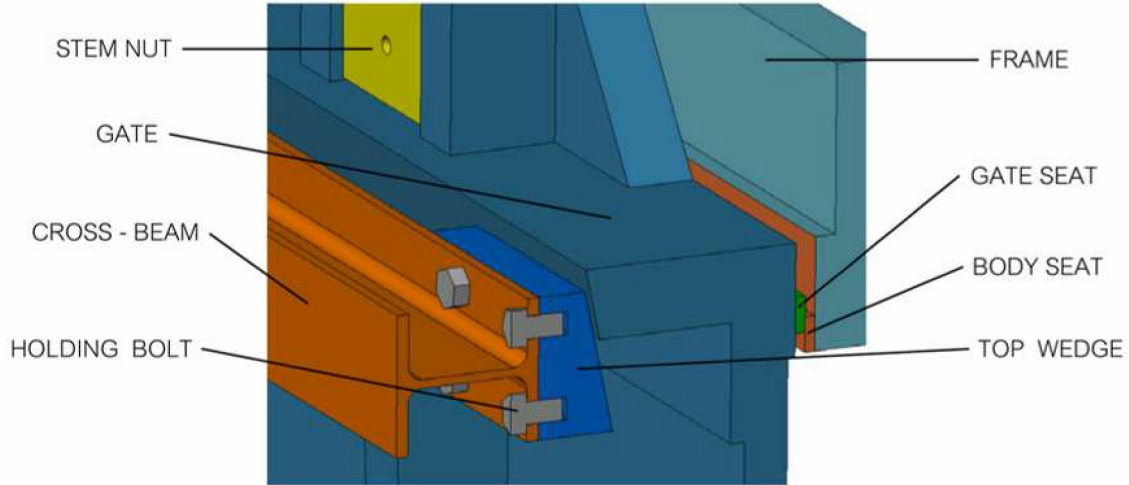

### TOP - WEDGE

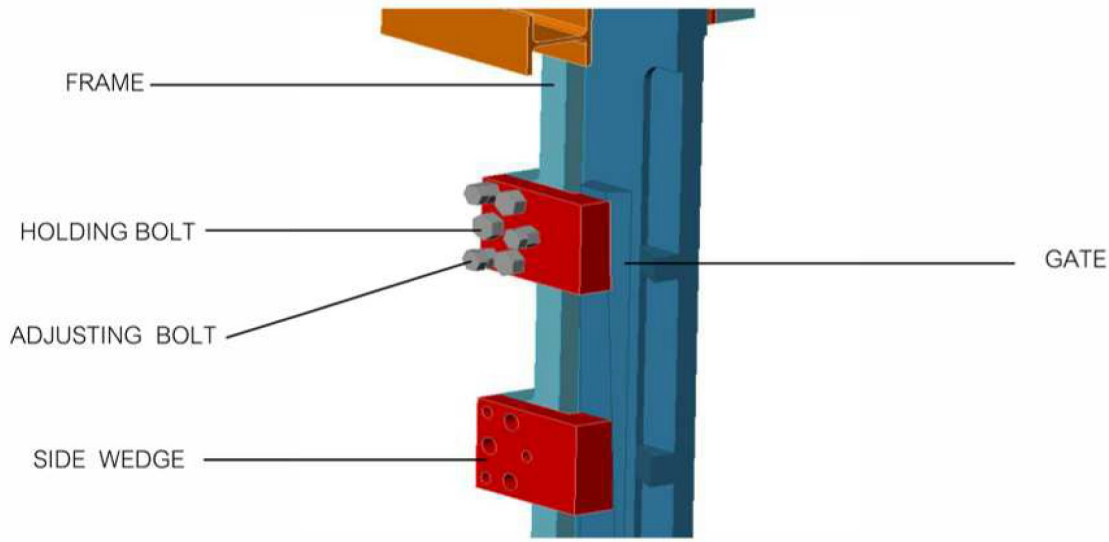

### SIDE - WEDGE

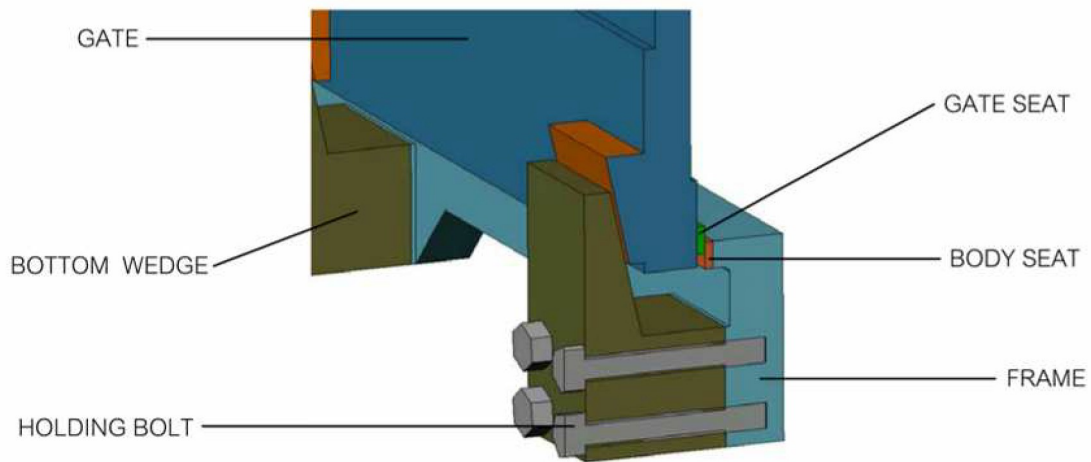

### BOTTOM - WEDGE

## D) TYPE OF PENSTOCK'S MOUNTED METHOD

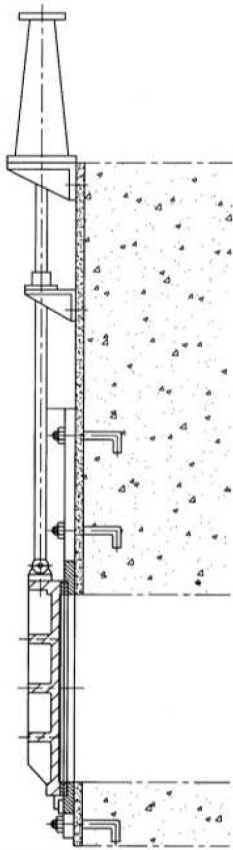

**Wall Mounted for Flat Back Type**

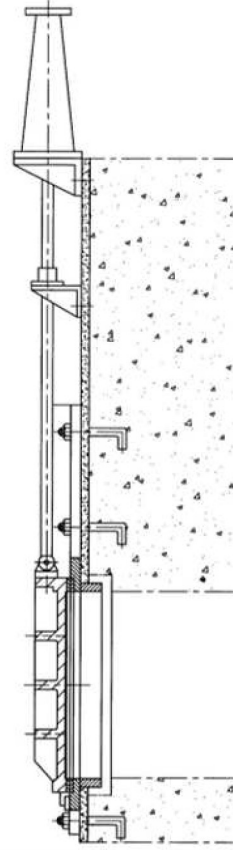

**Wall Mounted for Spigot Type**

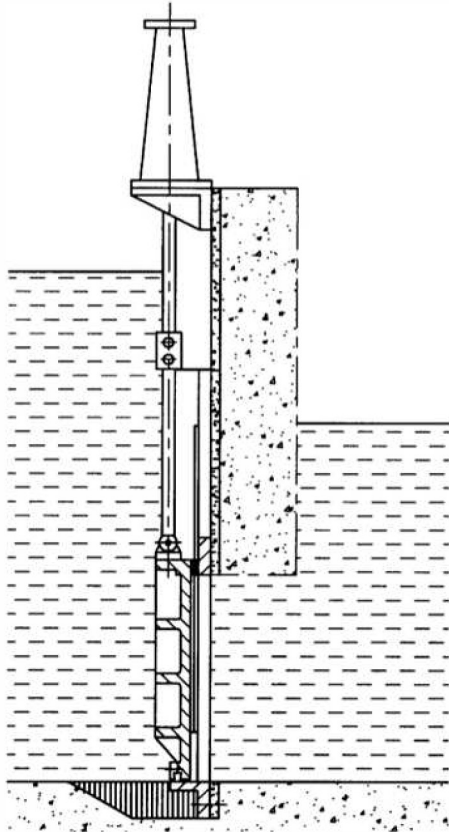

**Flush Bottom Mounted Method**

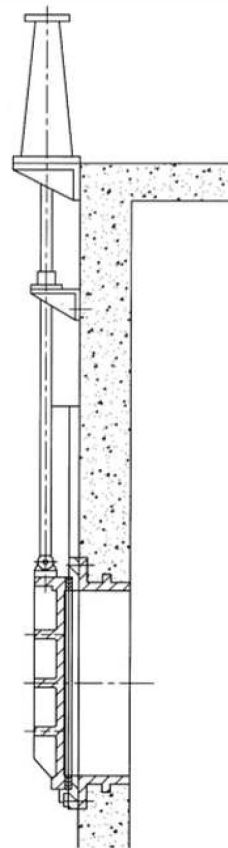

**Thimble or Pipe Flanging Mounted Method**

## J) PENSTOCK INSTASLLATOIN METHOD

### Penstock Receiving

Check all parts of penstock and accessories immediately after received from the delivery. Penstock is a precision machinery items that should be handled coeectly. Those improper storage and handling can cause the poor performance of penstock. During penstock handling, penstock must be supported by full length to avoid the structural twisting.Penstock must be stored in clean and dry environment to prevent distortion. Cover all equipment to protect machined surface. Do not stack equipment without protection. If the frame and gate are received and assembled together, do not separate them unless absolutely necessary. (If it is essential that they should be separated, clean the faces of gate, frame and wedges thoroughly before reassembling. ) Do not paint bronze and stainless steel surface.

### Installation Method

1. The concrete wall have to be lever perpendicular with ground. Mark the drilling position. Drilling hold on the concrete wall and install the chemical anchor bolt. (Figure No.1)

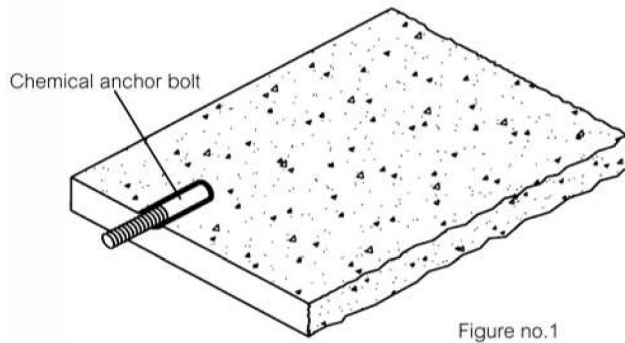

2. Install the Penstock to chemical anchor bolt and adjust 2 nuts to set the alignment of vertical and horizontal level. After the Penstock has been set, tighten nut to chemical anchor bolt to fix the Penstock. (Figure no.2)

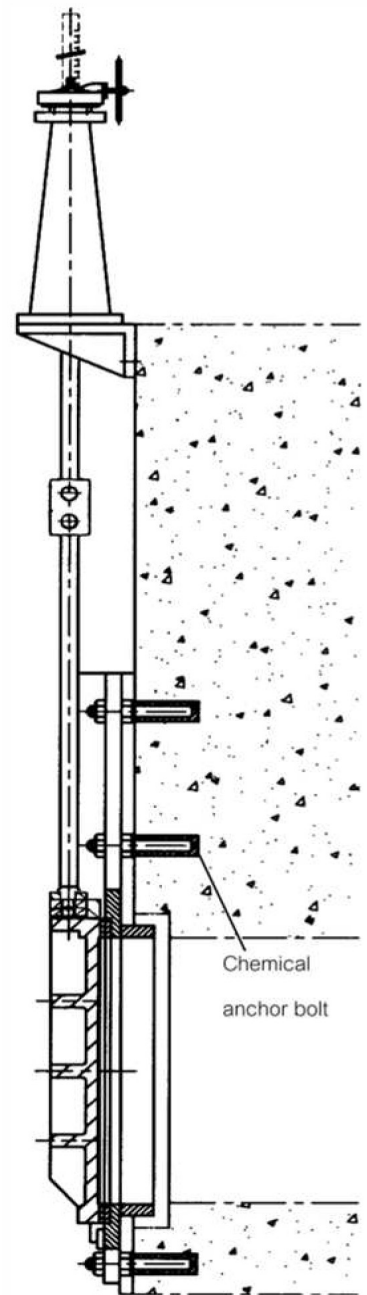
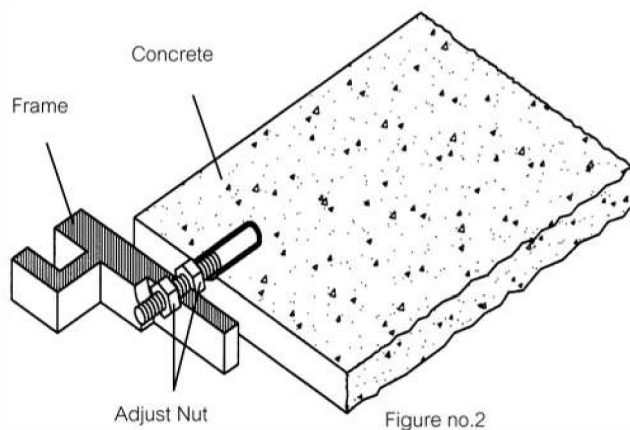

3. Insert the 0.1 mm. Filler gauge between gate and frame to check the leakage. ( Set the penstock until there is no leakage between gate and frame.) (Figure. no.3)

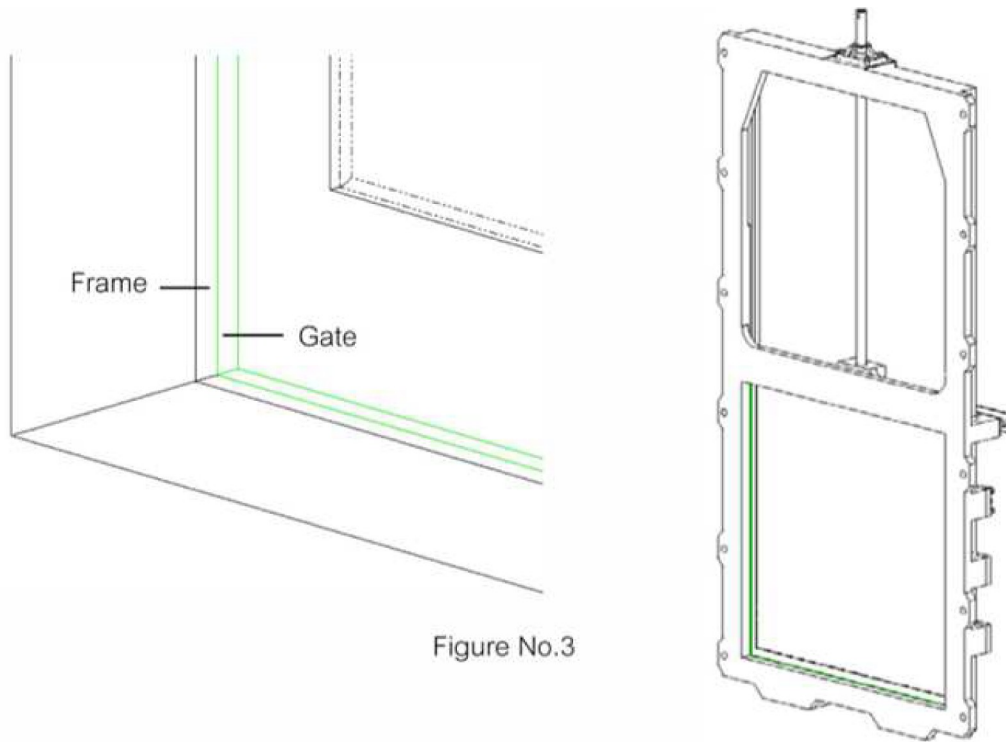

Figure No.3

4. Pour the grout between wall and frame (Figure.no.4)

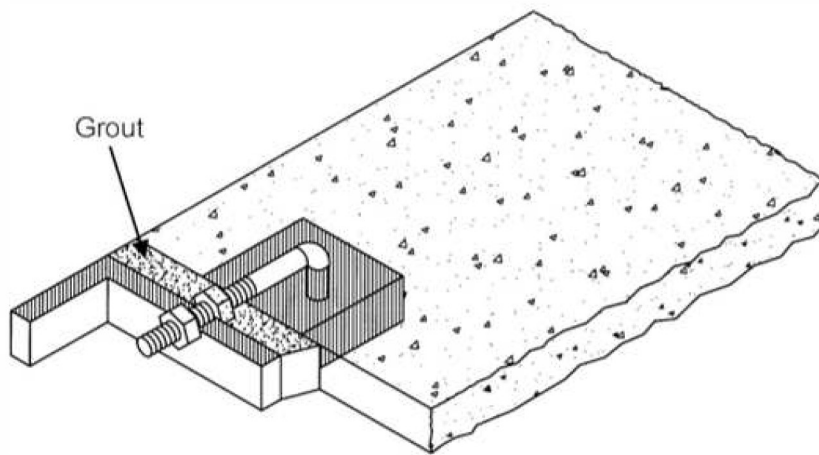

Figure.No.4

The torque of all bolts should then be done in several graduate steps. The bolts should be loaded evenly.

## K) DISCHARGE THROUGH PENSTOCK

